

# ATEX

## Operate safely in explosive environments

TRANSLYFT is certified to design and manufacture ATEX solutions. ATEX is short for "Atmospheres Explosibles". It is a set of European Union regulations that are designed to ensure the safety of products being used in explosive environments. The ATEX components eliminate the possibility of sparks occurring while the machine is in use. TRANSLYFT manufacture explosion proof equipment for ATEX zones: **1, 2, 21 and 22**

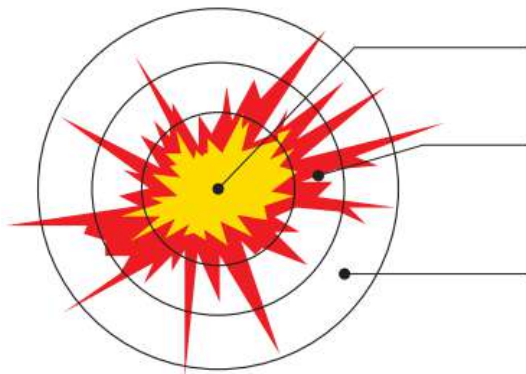

### Area 0 / 20

Permanent presence explosive atmospheres

### Area 1 / 21

Accidental presence of explosive atmospheres during the normal operation

### Area 2 / 22

Presence of atmospheres only in case of accident but not during the normal service

### FEATURE

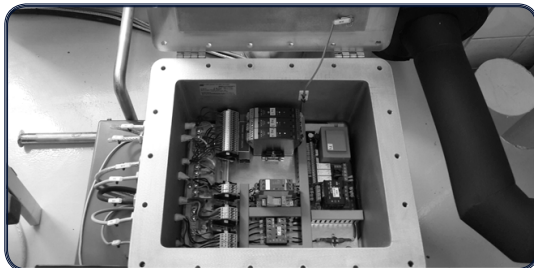

A power pack inside an ATEX zone i secured inside a pressure safe and gas/dust box.

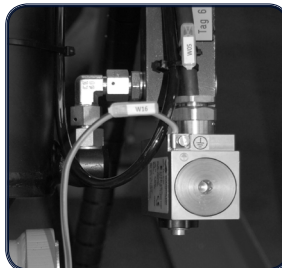

The solenoid valve is explosion proof.



The power pack can also be mounted outside the ATEX zone

In general terms, TRANSLYFT offer two ATEX options. A fully ATEX approved solution where every component is placed inside the ATEX zone or a partial ATEX approved solution.

Every ATEX solution is unique and when the specifics are in place we will produce a lifting solution without plastic parts, with specific electricity, wiring, pressure proof boxes, shielding and everything necessary to create the perfect ATEX lifting table for you.

When you order an ATEX solution you will need to fill out a specific order questionnaire defining zone, temperature and many other specifics (see next page). All components will be listed in a comprehensive O and M manual, including thorough safety instructions. Before shipment the table will be inspected by an external certification company.

### WHAT TO CONSIDER

Which zone and classes (temperature and gas or dust)?

Does the power pack need to be in the ATEX zone?

When the table is delivered and installed - will there need to be an inspection to certify the ATEX solution?

# ATEX - Questionnaire



To:

Att.:

From: Company:

Contact:

Telephone:

Telefax:

Products ref:

Products comments:

Date: Sign:

**NOTE: It is a requirement that Translyft receive information on all operating conditions in order to confirm the ATEX classification of the lifting table.**

**Please send the enquiry to infoireland@translyft.com (Remember to sign the document)**

**Place of lifting table:**

**Place of hydraulic aggregate & control:**

## Zone classification acc. ATEX-directive 1999/92/EC (gasses & vapours)

No zone     Zone 1     Zone 2

**Temperature class:**

T1     T2     T3

T4     T5     T6

**Gas class:**

IIA     IIB     IIC

No zone     Zone 1     Zone 2

**Temperature class:**

T1     T2     T3

T4     T5     T6

**Gas class:**

IIA     IIB     IIC

**Place of lifting table:**

**Place of hydraulic aggregate & control:**

## Zone classification acc. ATEX-directive 1999/92/EC (dust)

No zone     Zone 21     Zone 22

**Max. ignition temperature for dust cloud:**  
°C \_\_\_\_\_

**Ignition temperature for 5 mm dust layer:**  
°C \_\_\_\_\_

**Type of dust:**

IIIA Combustible dust floating  
 IIIB Non-conductive dust  
 IIIC Conductive dust

No zone     Zone 21     Zone 22

**Max. ignition temperature for dust cloud:**  
°C \_\_\_\_\_

**Ignition temperature for 5 mm dust layer:**  
°C \_\_\_\_\_

**Type of dust:**

IIIA Combustible dust floating  
 IIIB Non-conductive dust  
 IIIC Conductive dust

**Special details, operation conditions, ambient conditions / Special requirements:**

Customer-Confirmation of Technical Data

Date

Customer Signature



# ATEX Solution Improves Working Conditions At Major Whisky Producer

A traditional whisky cask filling operation in Scotland needed to improve the manual handling and ergonomic working position for its workers. The process involves the filling of various sizes of wooden casks with spirit which are then automatically handled on a chain conveyor system for loading and placing in bond to mature.



## The Challenge

As the casks are made from natural material, not all are perfect and require small repairs to stop leaks. The leaking casks are rejected from the system into a workshop area manned by Coopers (traditional skilled trade of making wooden barrels and casks). The repair work was carried out at floor level, with lots of bending, lifting and turning by hand of the casks.

A lifting table needed to be designed that could safely accommodate varying diameters and weights of casks. In addition to holding them securely, the area is an ATEX Zone 2 due the release of explosive ethanol.

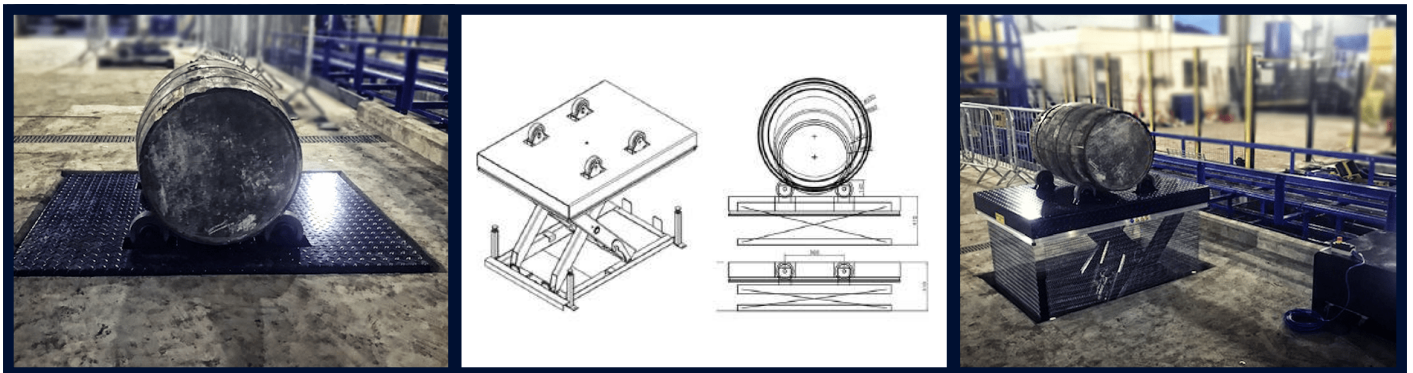

## The Solution

TRANSLYFT produced an initial design concept using castor wheels for holding the casks, and this was discussed with the client and their workers. Small adjustments were agreed and final drawings were then produced for approval before manufacture.



## The results

The mechanism was incorporated into an additional platform which was then mounted on a standard TRANSLYFT TL2000 single scissor action lift table. The table was then mounted in a pit to allow the casks to be rolled into position over the retracting castors. When the table raises the castors deploy around the cask securing it for work at the operators desired height.

The lift power pack and controls were built and certified for use in the ATEX Zone 2 environment.

*"The adjustable working height has reduced the number of back issues experienced by our Coopers. The process is altogether faster and safer now with the lift table installed in the work shop"*

Production Engineer, Cambus TCFS



Block B, The Crescent Building, Northwood, Santry, Dublin D09 C6X8  
tel.: 01 893 4994, mail: [infoireland@translyft.com](mailto:infoireland@translyft.com)